

USER MANUAL

i-2 UVA



i-2 SERIES DIMENSIONS

STANDARD VERSION

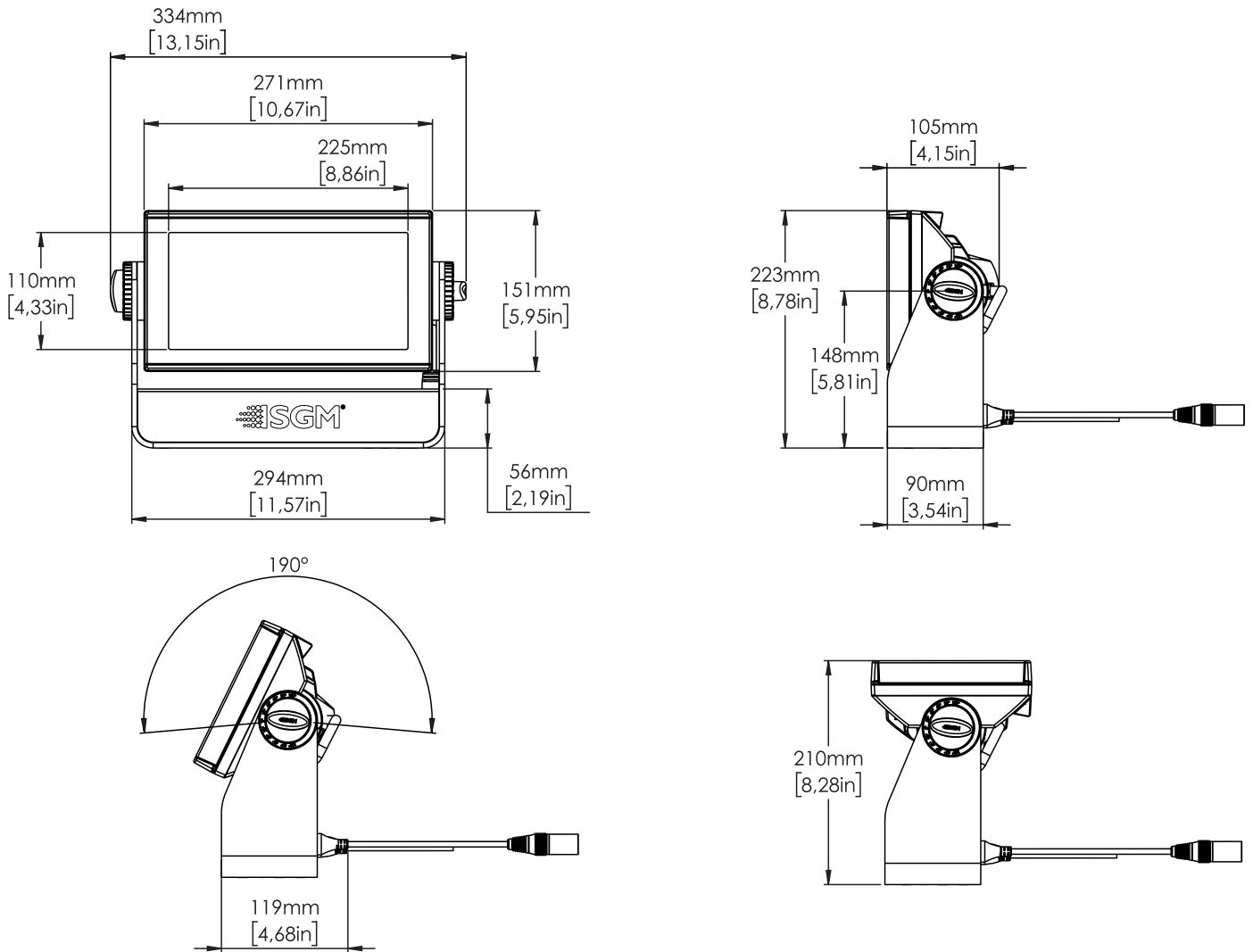

All dimensions in millimeters and inches. Drawing not to scale

This manual covers installation, use, and maintenance of the SGM i-2 UVA. A digital version is available at www.sgmlight.com or upon request via support@sgmlight.com. The information in this document is subject to change without notice. SGM and all affiliated companies disclaim liability for any injury, damage, direct or indirect loss, consequential or economic loss, or any other loss occasioned by the use of, inability to use, or reliance on the information contained in this manual. The SGM logo, the SGM name, and all other trademarks in this document pertaining to SGM services or SGM products are trademarks owned or licensed by SGM, its affiliates, and subsidiaries. This edition applies to firmware version 2.35 or later.

English edition © 2022 SGM Light A/S®.

i-2 UVA POI

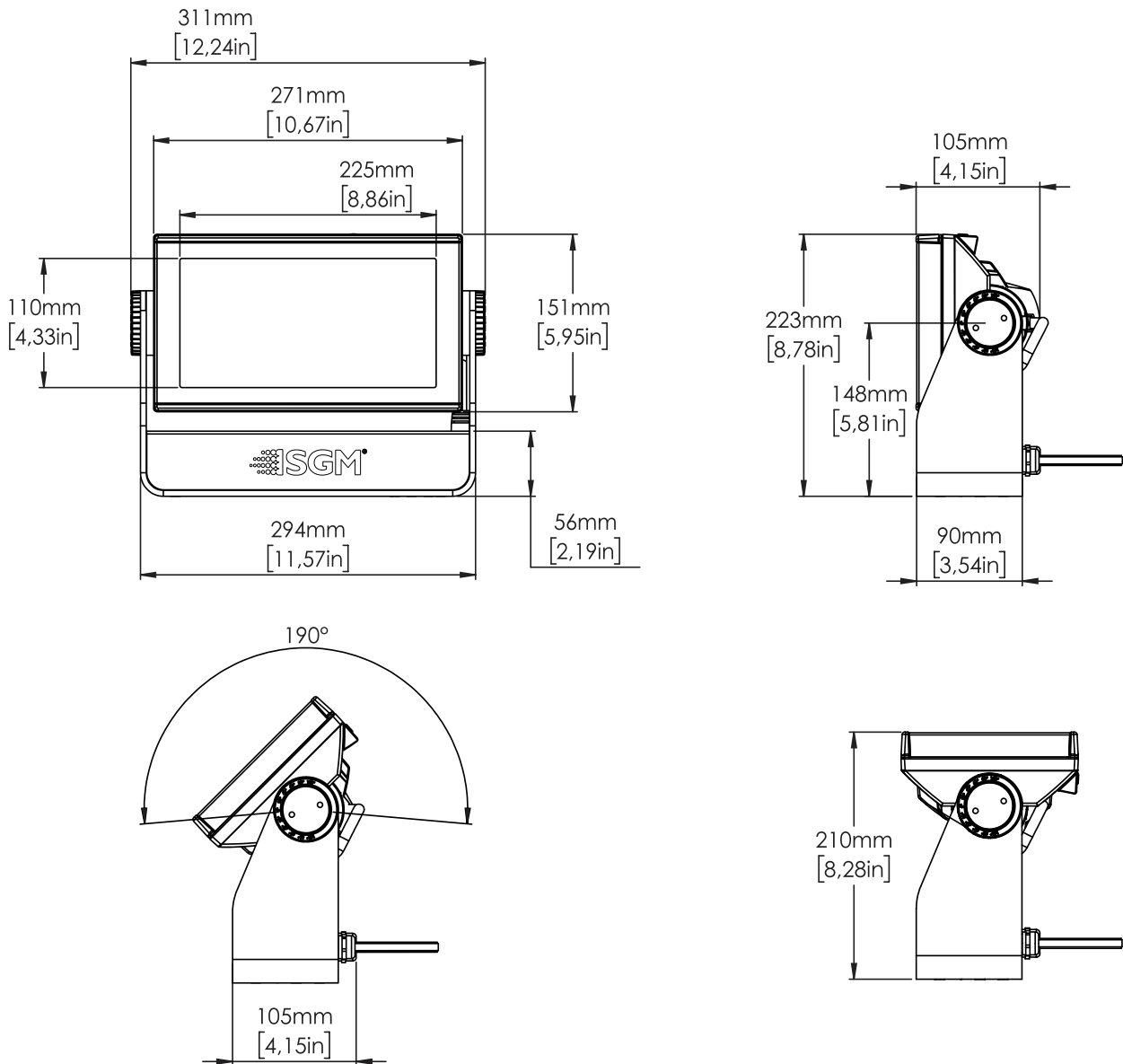

All dimensions in millimetres and inches. Drawing not to scale

2 i-2 SERIES DIMENSIONS

- 2 Standard version
- 3 i-2 UVA POI

6 SAFETY INFORMATION

8 BEFORE INSTALLING THIS PRODUCT

9 INSTALLATION STANDARD FIXTURE

- 9 Identification and terminology
- 10 Unpacking
- 10 Application considerations
- 10 Transport handling
- 10 Rigging
- 11 Rigging process using SGM Omega brackets
- 12 Tilt lock
- 12 Power requirements
- 13 Connecting power
- 13 Connecting a wireless transmitter
- 13 Signal priority
- 14 Mounting bracket

15 INSTALLATION POI FIXTURE

- 15 Identification and terminology
- 16 Unpacking
- 16 Application considerations
- 16 Connecting temporary signal
- 17 Settings and Fixture Defaults
- 18 Wireless Data Connection
- 18 LED Indicator Behaviour
- 18 Mounting
- 19 Brackets
- 20 Flat Bracket attachment
- 20 Omega Bracket attachment
- 21 Universal Bracket attachment
- 22 Wall Bracket attachment
- 23 POI Tilt Lock
- 24 Permanently Connecting Power & Data
- 25 Wireless

26 USER INTERFACE

- 26 Using the display panel
- 26 Shortcuts

27 DISPLAY

- 27 Operational mode (A)
- 27 DMX Address (B)
- 27 External data indicator (C)
- 27 External data protocol (D)
- 27 Error Indicator

28 CONFIGURING THE DEVICE FOR DMX CONTROL

- 28 About DMX
- 28 DMX Start address
- 28 Set/edit DMX address
- 28 Setting the DMX mode
- 28 DMX charts

29 USING STANDALONE OPERATION

30 FIXTURE PROPERTIES

- 30 Factory default
- 30 LED ENGINE
- 30 Individual fixture settings

31 CONTROL MENU

32 RDM

- 32 Supported RDM functions
- 32 Sensors

33 ACCESSORIES

- 33 Accessory holder
- 33 Barndoors
- 33 Floorstand

34 MAINTENANCE

- 34 Anti-glare shields
- 34 SGM Vacuum Test kit
- 35 Firmware Updates
- 36 Cleaning

36 TROUBLESHOOTING

37 FIXTURES AND ACCESSORIES

- 37 Ordering information
- 37 i-2 UVA accessories

37 SUPPORT HOTLINE

38 APPROVALS AND CERTIFICATIONS

39 USER NOTES



WARNING! READ THE FOLLOWING SAFETY PRECAUTIONS CAREFULLY BEFORE UNPACKING, INSTALLING, POWERING OR OPERATING THE DEVICE.



SGM fixtures are intended for professional use only. They are not suitable for household use.

Les fixtures SGM sont impropre à l'usage domestique. Uniquement à usage professionnel.

This product must be installed in accordance with the applicable installation code by a person familiar with the construction and operation of the product and the hazards involved.

Ce produit doit être installé selon le code d'installation pertinent, par une personne qui connaît bien le produit et son fonctionnement ainsi que les risques inhérent.



DANGER! RISK OF ELECTRIC SHOCK DO NOT OPEN THE DEVICE!

- Always power off/unplug the fixture before removing covers or dismantling the product.
- Ensure that the mains power is cut off when wiring the device to the AC mains supply.
- Ensure that the device is electrically connected to earth (ground).
- Do not apply power if the device or mains cable is in any way damaged.
- Do not immerse the fixture in water or liquid.



WARNING! TAKE MEASURES TO PREVENT BURNS AND FIRE!

- Install in a location that prevents accidental contact with the device.
- Install only in a well-ventilated space.
- Install at least 0.3 m (12 in.) away from objects to be illuminated.
- Install only in accordance with applicable building codes.
- Ensure a minimum clearance of 0.3 m (12 in.) around the cooling fans
- Do not paint, cover, or modify the device, and do not filter or mask the light.
- Keep all flammable materials well away from the device.

ALLOW THE DEVICE TO COOL FOR 15 MINUTES AFTER OPERATION BEFORE TOUCHING IT
CAUTION: EXTERIOR SURFACE TEMPERATURE AFTER 5 MIN. OPERATION = 42°C (108°F).
STEADY STATE = 48°C (118°F).



WARNING! TAKE MEASURES TO PREVENT PERSONAL INJURY. DO NOT LOOK DIRECTLY AT THE LIGHT SOURCE FROM CLOSE RANGE.

- Take precautions when working at height to prevent injury due to falls.
- For Permanent Outdoor Installations (POI), ensure that the fixture is securely fastened to a load-bearing surface with suitable corrosion-resistant hardware.
- For a temporary installation with clamps, ensure that the quarter-turn fasteners are turned fully and secured with a suitable safety cable. The standard safety wire cable must be approved for a safe working load (SWL) of 10 times the weight of the fixture, made of a grade AISI 316 steel, and it must have a minimum gauge of 4 mm.
- For elevated installations, secure the fixture with suitable safety cables, and always comply with relevant load dimensioning, safety standards, and requirements.



WARNING! UV EMITTED FROM THIS PRODUCT

PHOTOBIOLOGICAL CLASSIFICATION: RISK GROUP 3

ATTENTION! UV ÉMIS PAR CE PRODUIT

CLASSIFICATION PHOTOBIOLOGIQUE: GROUPE DE RISQUE 3



CAUTION – RISK OF PERSONAL INJURY.

THIS LED ARRAY IS NOT INTENDED FOR GENERAL ILLUMINATION AND MAY REQUIRE THE USE OF SPECIAL SAFEGUARDS. INSTALL AND USE ONLY IN STRICT ACCORDANCE WITH THE PRODUCT AND PACKAGING MARKINGS.



ATTENTION – RISQUE DE BLESSURE PERSONNELLE.

CE TABLEAU DE LED N'EST PAS DESTINÉ AUX GÉNÉRAUX L'ÉCLAIRAGE ET PEUT NÉCESSAIRE L'UTILISATION DE GARANTIES SPÉCIALES. INSTALLER ET UTILISER UNIQUEMENT EN CONFORMITÉ STRICTE AVEC LES MARQUAGES DU PRODUIT ET DE L'EMBALLAGE.



DANGER! ULTRAVIOLET EXPOSURE

Photobiological Risk Group 3. This luminaire emits ultraviolet (UV) radiation around 365nm. UV emission is harmful to the eyes, skin and retina. Avoid looking at UV LEDs directly, and never look directly at the luminaire when powered on at distances shorter than 3.3' (1m). Minimize direct and prolonged exposure to UV radiation and avoid eye and skin exposure at distances shorter than 15' (4.6m) Do not view the beam directly with optics that may concentrate the light/radiation output. Those with sunlight exposure disorders or individuals receiving photosensitive medication may receive discomfort if exposed to ultraviolet light.



DANGER! EXPOSITION AUX ULTRAVIOLETS

Groupe de risque photobiologique 3. Ce luminaire émet un rayonnement ultraviolet (UV) d'environ 365 nm. Les émissions d'UV sont nocives pour les yeux, la peau et la rétine. Évitez de regarder directement les LED UV et ne regardez jamais directement le luminaire lorsqu'il est allumé à des distances inférieures à 3,3 '(1 m). Minimisez l'exposition directe et prolongée aux rayons UV et évitez l'exposition des yeux et de la peau à des distances inférieures à 15' (4,6 m). Ne regardez pas le faisceau directement avec des optiques susceptibles de concentrer la lumière/le rayonnement émis. Les personnes souffrant de troubles de l'exposition au soleil ou les personnes recevant des médicaments photosensibles peuvent ressentir une gêne si elles sont exposées à la lumière ultraviolette.

BEFORE INSTALLING THIS PRODUCT

Please visit the SGM official website at sgmlight.com for the latest version of this user manual / safety information leaflet. Due to continuous improvements, the instructions may change without notice. SGM always recommends the latest available firmware version from sgmlight.com.



EXTERNAL CLEANING AND VISUAL INSPECTION OF THE FIXTURE:

All users of SGM fixtures should regularly clean those parts of the fixture directly exposed to the elements, such as the external housing and front lenses. Additionally, all owners of SGM fixtures must periodically check the external housing of the fixture for structural breaks, components in bad shape, cracked lenses, or loose screws. To ensure proper operation, but also to prevent the risk of potential accidents, do not use the fixture if the lens, housing, or power cables are damaged. If parts of the fixture appear to be missing, cease use immediately and contact SGM support.



WIRING AND CONDUIT / CONTAINMENT:

SGM fixtures supplied with power and data cable leads are not intended for installation in permanently installed conduit or containment. When installing fixtures in a permanent installation, ensure cable leads are installed as a service loop to an appropriately rated junction box using suitable cable strain reliefs / glands. All installed fixtures must be securely mounted and service loop appropriately protected for installation location. All electrical wiring and connections should be completed by a qualified electrician.



SAFETY PRECAUTIONS

When using electrical equipment, basic safety precautions should always be followed including the following:

- 1. Do not mount near gas or electric heaters.
- 2. Permanently installed equipment should be mounted in locations and at heights where it will not readily be subjected to tampering by unauthorized personnel.
- 3. The use of accessory equipment not recommended by the manufacturer may cause an unsafe condition.
- 4. Do not use this equipment for other than intended use.
- 5. Refer service to qualified personnel or authorized service centers.
- 6. Do not look directly into the beam for long periods of time, when the fixture is on.
- 7. The fixture shall, under no circumstance, be covered with insulating material of any kind.

READ AND FOLLOW ALL SAFETY INSTRUCTIONS

IDENTIFICATION AND TERMINOLOGY

- A: 63 UV-A LEDs
- B: Tilt lock
- C: Cooling fan
- D: Control panel
- E: OLED Display
- F: DMX in and out
- G: Safety wire attachment point
- H: Dehumidifiers and GORE-TEX membranes
- I: Holes for Omega bracket
- J: Power cable

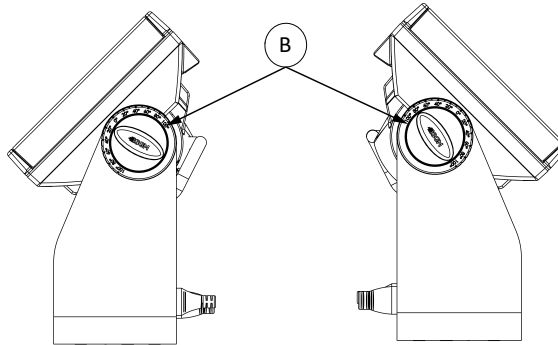
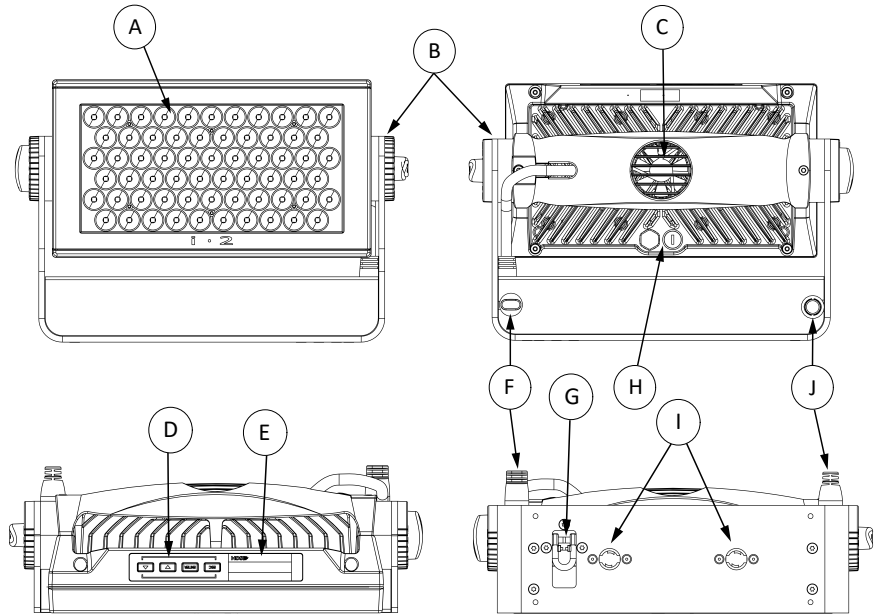

Illustrations might vary from received products. This is subject to change without notice.

UNPACKING

Unpack the device and inspect it to ensure that it has not been damaged during transport.

The fixture is shipped with:

- 1 x omega bracket with 1/4-turn fasteners (standard only)
- 1 x mounting bracket with fasteners (standard only)
- Safety information leaflet
- 2 m IP66 power cable pigtail

APPLICATION CONSIDERATIONS

The standard fixture is IP65-rated and is designed for both indoor and outdoor events. This means that it is protected from:

- Dust, to the degree that dust cannot enter the fixture in sufficient quantities as to interfere with its operation.
- High pressure water jets of water from any direction.

When selecting a location for the device, ensure that:

- It is situated away from public thoroughfares and protected from contact with people.
- It has adequate ventilation.
- It is not immersed in water.

When using standard fixtures outdoors or in wet locations, ensure that:

- The DMX out of the last fixture is properly sealed, in accordance with the ingress protection (IP) requirements.
- The DMX out of the last fixture is terminated with a 120 ohm resistor between pin 2 and 3 (according to the RS485 standard), and the DMX out is properly sealed, in accordance with the ingress protection (IP) requirements. Note that there can be connected a maximum of 32 fixtures to the same DMX link.

TRANSPORT HANDLING

Always use the supplied packaging or suitable flight case for transportation and storage. Never carry the fixture by connected cables or wires.

RIGGING

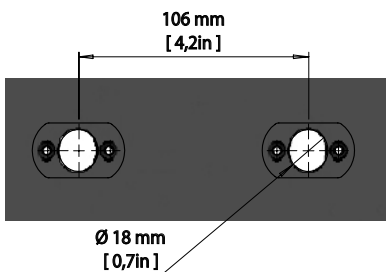

Figure 1: Locking points

The fixture may be installed in any orientation, on the ceiling or on a wall surface.

When installed horizontally with a downward beam-angle, water, moist, or grime can potentially pool in the fan wells. Under normal operation the moisture will evaporate.

In locations with high rainfall, you may wish to fabricate a rain shield above the fixture, or modify the position and orientation of the fixture to minimize pooling.

All SGM fixtures have locking points at the base for installation and rigging. In both standard and POI fixtures, the distance between the points from center to center is always 106 mm. However, while the base of the standard fixture includes 1/4-turn fastener camlocks to mount the omega brackets, the POI products come with M-10 nuts for M-10 screws.

Always use the supplied omega bracket to rig a standard fixture. Lock the bracket with the 1/4-turn fasteners.

PLEASE NOTE! THE 1/4-TURN FASTENERS ARE ONLY LOCKED WHEN TURNED FULLY CLOCKWISE. DEPENDING ON THE STRUCTURE, PLEASE USE APPROPRIATE AND SECURE METHODS FOR MOUNTING THE OMEGA BRACKETS.

PLEASE NOTE! THE SUPPLIED OMEGA BRACKET IS NOT RATED FOR PERMANENT OUTDOOR INSTALLATION (POI). FOR MORE INFORMATION, SEE IN "MOUNTING" ON PAGE 18 (PERMANENT OUTDOOR INSTALLATION) .

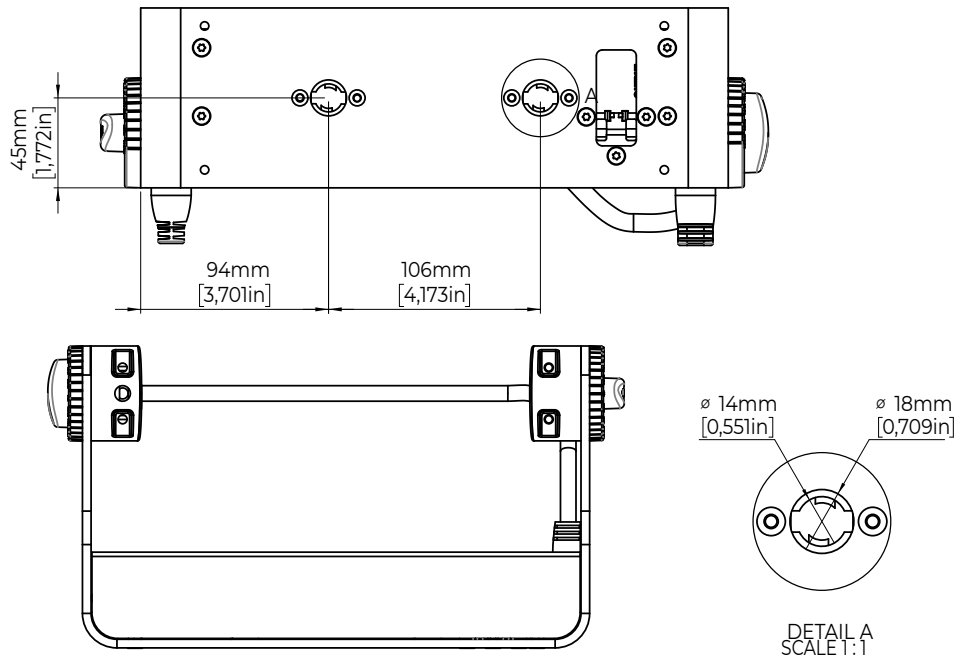

Figure 2: Dimensions for i-2 UVA base locking points

RIGGING PROCESS USING SGM OMEGA BRACKETS

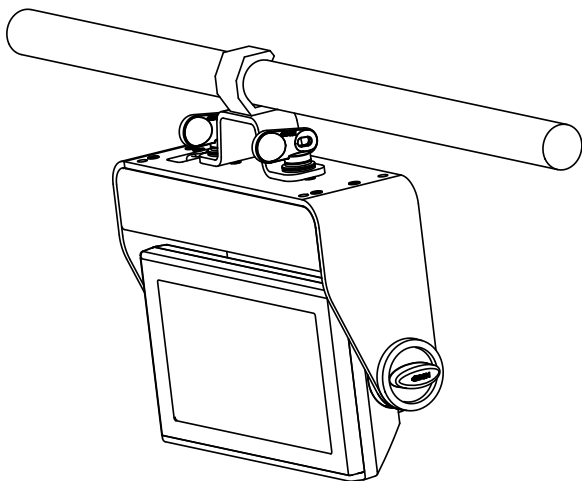

Figure 3: Installing the i-2 UVA

Start the standard rigging process by blocking the lower working area, and make sure the work is performed from a stable platform.

1. Check that the clamp/bracket is undamaged and can bear at least 10 times the weight of the fixture. Check that the structure can bear at least 10 times the weight of all installed fixtures, lamps, cables etc.
2. Bolt the clamp/bracket securely to the omega bracket with a M12/ 1/2 bolt (min. grade 8.8) and a lock nut.
3. Align the omega bracket with the fixture base. For standard omega bracket, insert the fasteners into the fixture base bracket, and turn both levers 1/4-turn clockwise to lock. When using the POI omega bracket, insert the included M-10 screws through the bracket holes and tighten with a M-10 key until they are fully attached to the base.
4. Working from a stable platform, hang the fixture on a truss or other structure. Tighten the clamp/bracket.
5. Install a safety wire that can bear at least 10 times the weight of the fixture. The safety wire attachment point is designed to fit a carabiner AISI316 grade.

6. Verify that there are no combustible materials, cables, or surfaces to be illuminated within 0.3 m (12 in.) of the fixture.

7. Check that there is no risk of the head/yoke colliding with other fixtures or structures.



WARNING! ALWAYS SECURE AN ELEVATED FIXTURE WITH A SAFETY WIRE. ALWAYS USE A SAFETY WIRE OF A GRADE AISI 316 STEEL. MAKE SURE THE SLACK OF THE SAFETY WIRE IS AT A MINIMUM. NEVER USE THE YOKE/HANDLE FOR SECONDARY ATTACHMENT.



Figure 4: Safety wire attachment point

Fasten a safety wire (not shown) between the load-bearing support structure and the safety wire attachment point on the device.

- The safety cable (not included in the package) must:
- Bear at least 10 times the weight of the device (SWL).
- Have a minimum gauge of 4 mm.
- Have a maximum length (free fall) = 30 cm (12 in.).

TILT LOCK

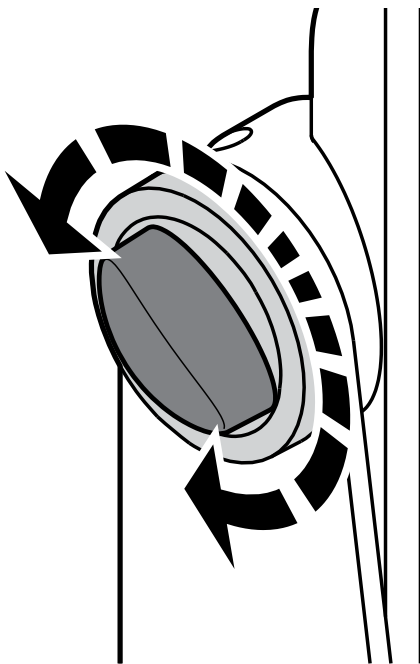

Figure 5: Standard tilt lock

The fixture can be tilted from 0° - 180°.

To adjust the tilt angle in standard versions:

1. Loosen the two tilt screws (one on each side) by turning them counter-clockwise.
2. Tilt the fixture to the angle desired and hold it.
3. Lock the position by re-tightening both tilt lock screws clockwise.

If resistance is encountered when tilting the fixture, you might not have loosened the tilt screws enough.

CAUTION!



ALWAYS ALLOW THE FIXTURE TO COOL DOWN FOR 15 MINUTES AFTER OPERATION BEFORE HANDLING.

POWER REQUIREMENTS

The fixture can operate on any 100–277 V, 50/60 Hz AC mains power supply, and draws a maximum of 190W.

Connect the fixture to AC power by installing a power connector to the bare end side of the supplied power cable. Connect the powercon twist-lock connector side to the fixture. The fixture must be grounded/earthed and be able to be isolated from AC power. The AC power supply must incorporate a fuse or circuit breaker for fault protection.

CONNECTING POWER

Wire	Color	Symbol	Conductor
	Black	L	live
	White	N	neutral
	green/yellow	⏏ or ⏚	ground (earth)

The power cable color coding is given in figure 6:

- Connect the black wire to live
- Connect the white wire to neutral
- Connect the green/yellow wire to ground (earth)

Figure 6: Connecting AC Power

For a temporary outdoor installation the mains cable must be fitted with a grounded connector intended for exterior use.

For permanent installations, have a qualified electrician wire the mains cable directly to a suitable branch circuit. Any cable management must have an appropriate (IP) rating suitable for the location. Always use a junction box with a proper IP class suitable for the environment.

After connecting the fixture to power, run the on-board test by selecting the option TEST → SELF-TEST in the menu to ensure that the fixture and each LED are functioning correctly. POI versions have to be tested through RDM.

PLEASE NOTE! THE PROTECTIVE CAPS MUST BE SECURELY MOUNTED ON ANY UNUSED CONNECTORS, IN ORDER TO MAINTAIN THE INGRESS PROTECTION (IP RATING).

CAUTION!

DO NOT OPEN THE FIXTURE TO REPLACE THE SUPPLIED POWER CABLE.

DO NOT CONNECT THE FIXTURE TO AN ELECTRICAL DIMMER SYSTEM, AS DOING SO MAY CAUSE DAMAGE.

CONNECTING A WIRELESS TRANSMITTER

The fixture is designed to look for wireless transmitters in 'connect' state when this option is not yet enabled. The fixture comes tested for wireless functionality from the factory, therefore the beginning of the pairing process is to disconnect from the factory wireless DMX transceiver.

To connect the fixture to a wireless transmitter:

Log off the currently paired wireless transmitter. Go to SETTINGS → WIRELESS DMX → LOG OFF in the menu. Fixture confirms logged off.

1. Press the connect button on the wireless transmitter.
2. Confirm that the fixture has paired with the wireless transmitter.

PLEASE NOTE! FOR POI VERSIONS, REFER TO "WIRELESS DATA CONNECTION".

SIGNAL PRIORITY

The fixture can be paired to an active wireless transmitter simultaneously when connected to a cabled DMX. The fixture will prioritize cabled DMX over wireless DMX.

The active input type is displayed under the wireless signal strength indicator. The signal strength can be also checked via RDM data by using an external RDM device.

PLEASE NOTE! IN POI VERSION WITH WIRELESS, THE DMX SIGNAL STRENGTH IS CHECKED THROUGH RDM.

MOUNTING BRACKET

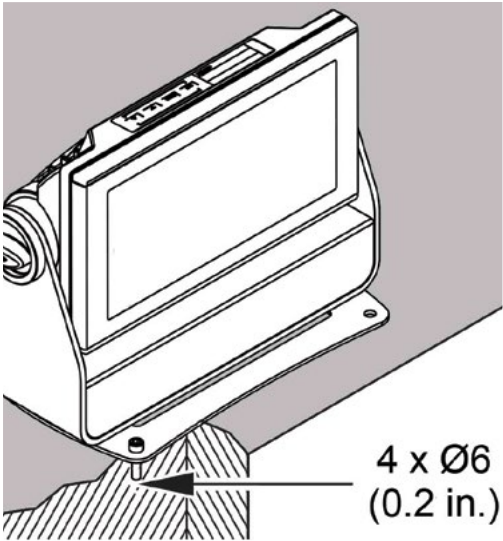

The standard fixture includes a mounting bracket with fasteners that can be attached to the fixture. The four rubber push-in bumpers prevent the fixture from sliding while operating, and protect delicate surfaces from scratching.

If a more secure mounting is required, remove the four rubber push-in bumpers from the mounting bracket. Then securely fasten the fixture on the ground/wall by using 4 x 6 mm (1/4 in.) fasteners on the resulting holes.

PLEASE NOTE! THE INCLUDED MOUNTING BRACKET IS NOT INTENDED FOR PERMANENT OUTDOOR INSTALLATION. REFER TO POI SECTION FOR OPTIONS.

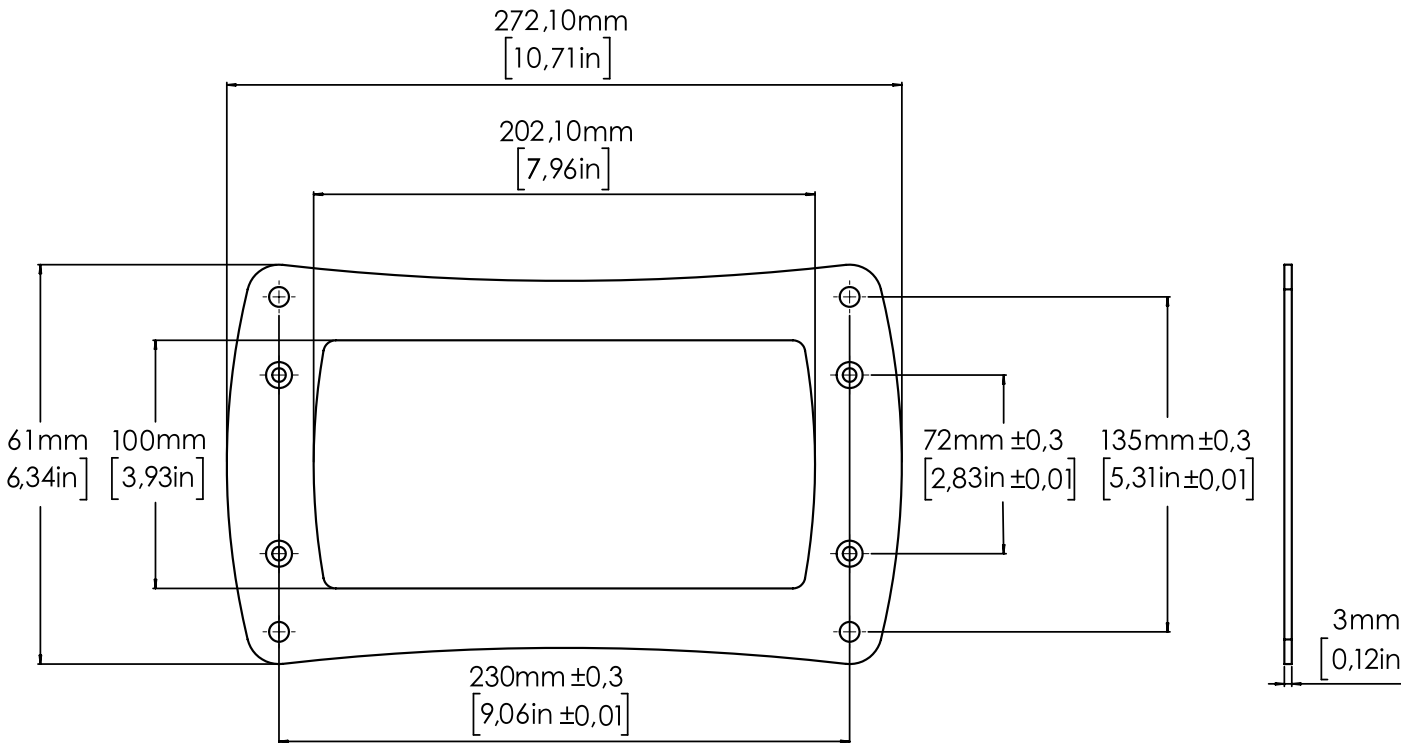
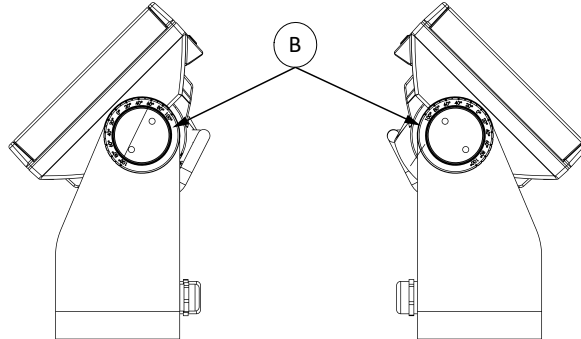
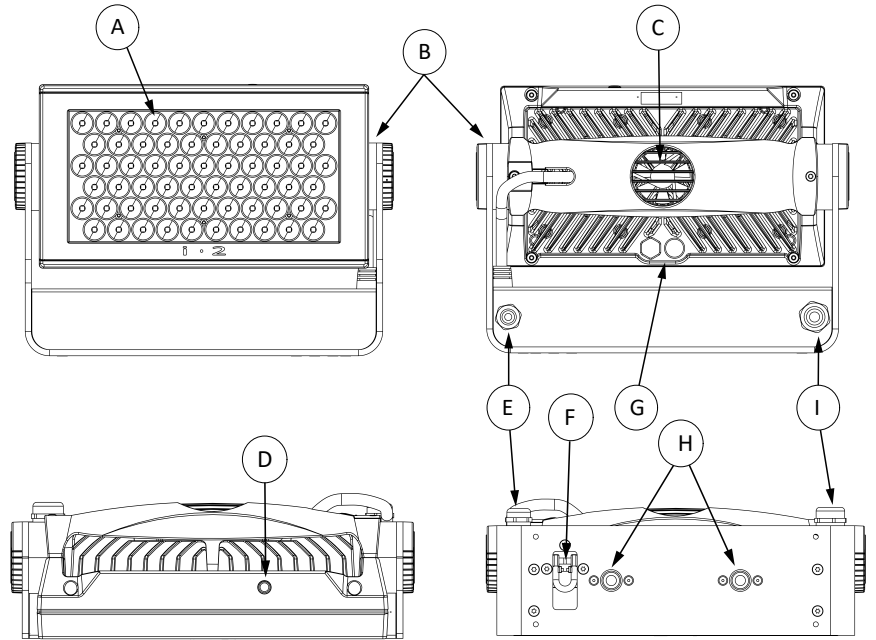

Figure 7: i-2 UVA mounting bracket

INSTALLATION POI FIXTURE

IDENTIFICATION AND TERMINOLOGY

- A: 63 UV-A LEDs
- B: POI Tilt lock
- C: Cooling fan
- D: LED indicator (POI only)
- E: DMX in and out
- F: Safety wire attachment point
- G: Dehumidifiers and GORE-TEX membranes
- H: Holes for Omega bracket / M-10 screws (x2)
- I: Power cable



Illustrations might vary from received products. This is subject to change without notice.

PLEASE NOTE! POI VERSION OF THE FIXTURE SHOULD BE PRESET WITH ANY CUSTOM PROGRAMMING BEFORE INSTALLATION. ALTHOUGH IT IS POSSIBLE FOR MOST FUNCTIONS TO BE SET VIA RDM ONCE MOUNTED IN POSITION, IT IS EASIER TO DO CONFIGURATION AND ANY TROUBLESHOOTING BEFORE MOUNTING IS COMPLETE.

UNPACKING

Unpack the device and inspect it to ensure that it has not been damaged during transport.

The i-2 UVA is shipped with:

- 1 x spanner with magnet (POI only).
- 2 x M-10 screws (POI Only).
- Safety information leaflet.

APPLICATION CONSIDERATIONS

The POI fixture is IP66-rated and designed for use in outdoor installations. This means that it is protected from:

- Dust, to the degree that dust cannot enter the device in sufficient quantities as to interfere with its operation.
- High pressure water jets from any direction.

When selecting a location for the device, ensure that:

- It is situated away from public thoroughfares and protected from contact with people.
- It has adequate ventilation.
- It is not immersed in water.

CONNECTING TEMPORARY POWER



Wire	Color	Symbol	Conductor
	Black	L	live
	White	N	neutral
	green/yellow	⏏ or ⏚	ground (earth)

Figure 8: Connecting AC Power

Connect to AC power using the supplied power cable. The fixture must be grounded/earthed. The AC power supply must incorporate a fuse or circuit breaker for fault protection. For temporary programming, a plug or terminals can be used.

The power cable color coding is shown on fig. 8:

- Connect the black wire to live
- Connect the white wire to neutral
- Connect the green/yellow wire to ground (earth)

CONNECTING TEMPORARY SIGNAL





Wire	Color	Conductor
	Shield	Ground
	White	DMX IN: Data -
	Red	DMX IN: Data +
	Black	DMX OUT: Data -
	Yellow	DMX OUT: Data +

Figure 9: Data wiring guide for setup

SGM fixtures use the DMX 512 standard for communication.

STEP 1: Download and install the SGM RDM Addressing tool.

< <https://sgmlight.com/products/rdm-addressing-tool> >

STEP 2: Connect the bare end data cable to the POI Up-loader cable for POI fixtures.

STEP 3: Connect the USB uploader cable for POI fixtures to a computer with a USB type-A port. When addressing through USB powered DMX/RDM devices, ensure the DMX link is terminated, and keep all cables as short as possible.

STEP 4: Launch the SGM RDM addressing tool. Repeat Steps 2-5 for more fixtures. Multiple fixtures can be addressed and configured. Contact your SGM representative for more information on multiple fixture addressing.



Figure 10: Connecting data to USB up-loader cable for POI fixtures

STEP 5: Step 5 Disconnect up-loader cable from computer, then disconnect up-loader cable from fixture.

Repeat Steps 2-5 for more fixtures. Multiple fixtures can be addressed and configured. Contact your SGM representative for more information on multiple fixture addressing.

PLEASE NOTE! AT A MINIMUM, ALL FIXTURES WILL NEED TO BE GIVEN A DMX ADDRESS AND DMX PERSONALITY IN ORDER TO PATCH AND PROGRAM ON A CONTROLLER.

SETTINGS AND FIXTURE DEFAULTS

All configuration of POI fixtures is done through the SGM Addressing Tool. The SGM Addressing Tool is a windows based program designed to allow the user to configure the fixture through the RDM protocol. All settings on a standard fixture are available on a POI fixture. But on POI, these settings are changed through the Addressing Tool.

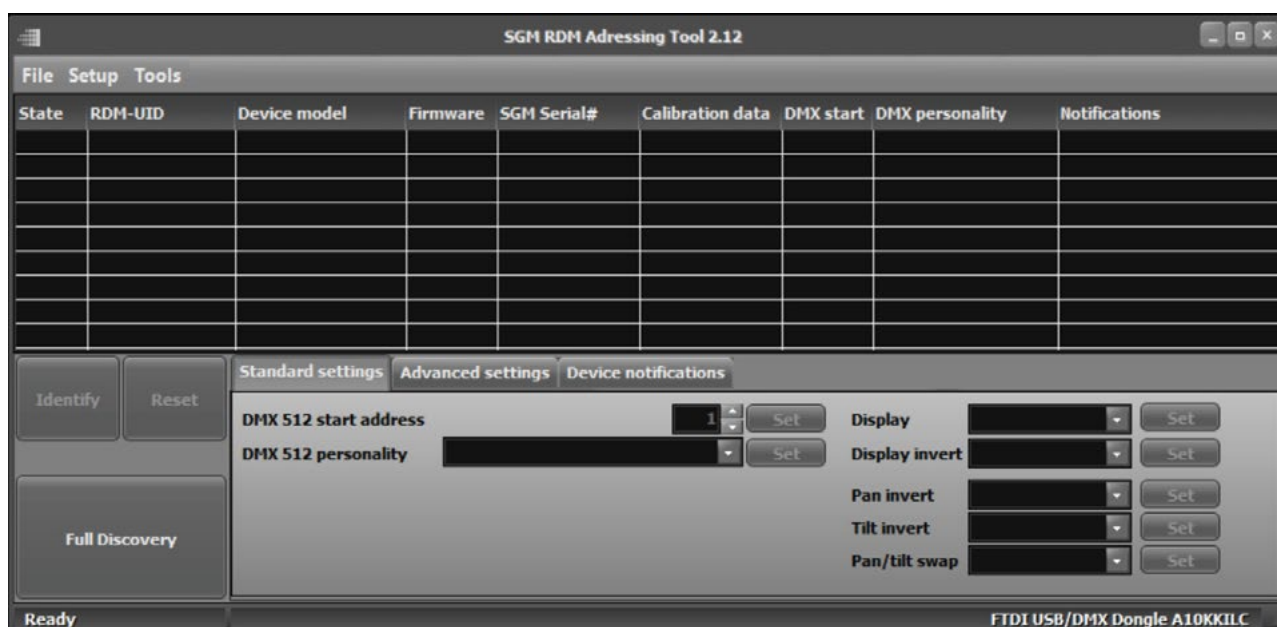

Figure 11: SGM Addressing tool

- STEP 1: Click Full Discovery and look for the green light to light up on the fixture. If the green light does not appear, cycle power or refer to troubleshooting.
- STEP 2: Select the standard settings tab and enter a DMX address and a personality/mode of operation. Look for the LED indicator to blink to confirm the settings change. DMX modes for POI are the same as for the standard. Visit www.sgmlight.com to see all DMX charts available under the respective product, or upon request via support@sgmlight.com.
- STEP 3: If necessary for the application, click advanced settings to set the fan mode, dimming curve, calibration, or to reset to factory defaults.
- STEP 4: Disconnect POI uploader cable.

Repeat as required for multiple fixtures.

PLEASE NOTE! REMOTE DEVICE MANAGEMENT (RDM) REQUIRES A CORRECTLY INSTALLED AND TERMINATED DMX CABLE.

When setting addresses through RDM and using USB dongles, it may be necessary to disable “USB selective suspend” to ensure a proper voltage to the DMX link. If any lag or trouble occurs when addressing, decrease the cable length range to <12 m. and only address one fixture at a time.

WIRELESS DATA CONNECTION

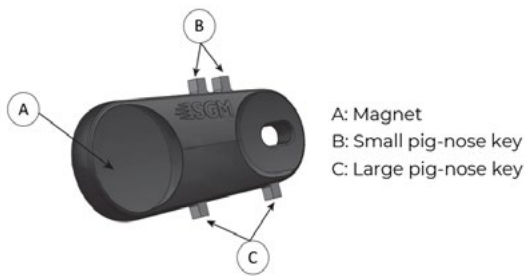

Figure 12: POI Spanner

To disconnect the fixture from the currently paired wireless transmitter, hold the magnet for 3 seconds over the LED indicator. The LED indicator will blink orange for 1-2 seconds, switching later to green again. The fixture is now logged off.

LED INDICATOR BEHAVIOUR

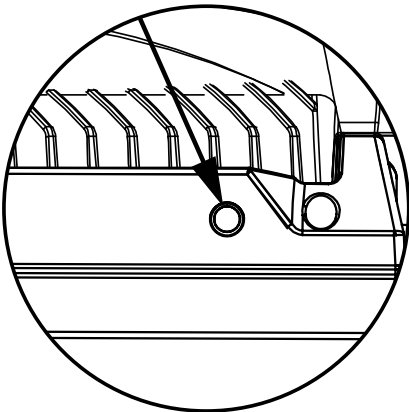

Figure 13: i-2 UVA POI LED indicator

The LED indicator can have different colours and three possible stages: static, flashing, or off.

- Solid Orange: fixture is starting up.
- Blinking Orange - Green: fixture is resetting its functions.
- Blinking Green: reset has completed, no errors and no wireless or wired DMX connection.
- Solid Green: wireless/wired DMX connected.
- Blinking Green - Orange - Red: fixture is resetting and error(s) has occurred during reset.
- Blinking Green - Red: reset has completed but error(s) occurred during reset.
- Solid Red (3 seconds): hall sensor is activated. When activated for longer than 3 seconds, wireless DMX connection is logged off.
- Off: fixture is off or LED indicator is set to auto-dimming (set via RDM). Once configuration is complete, temporary power and data can be disconnected.

MOUNTING

While the base of the standard products includes 1/4-turn fastener camlocks for omega brackets, the base of POI products comes with M-10 nuts for M-10 screws. The M-10 screws are included in the package in the same amount as the number of M-10 nuts of the base.

The POI fixture has two M-10 nuts at the base that can be used for installation and rigging. The SGM omega bracket (not included) or a customized bracket is needed to install the fixture. Consider the dimensions below of the POI fixture base for customized mounting brackets purposes.

The SGM POI omega bracket suited for M-10 holes can be ordered as an accessory. Contact your local SGM dealer for further information on correct POI-rated mounting.

PLEASE NOTE! ENSURE THAT HARDWARE AND BRACKETS USED FOR MOUNTING IS A COMPATIBLE MATERIAL WITH ALL COMPONENTS. GALVANIC REACTIONS CAN HAPPEN IN HIGHLY CORROSIVE ENVIRONMENTS. IMPROPER HARDWARE AND SELECTION OF MOUNTING MATERIALS COULD VOID WARRANTY.

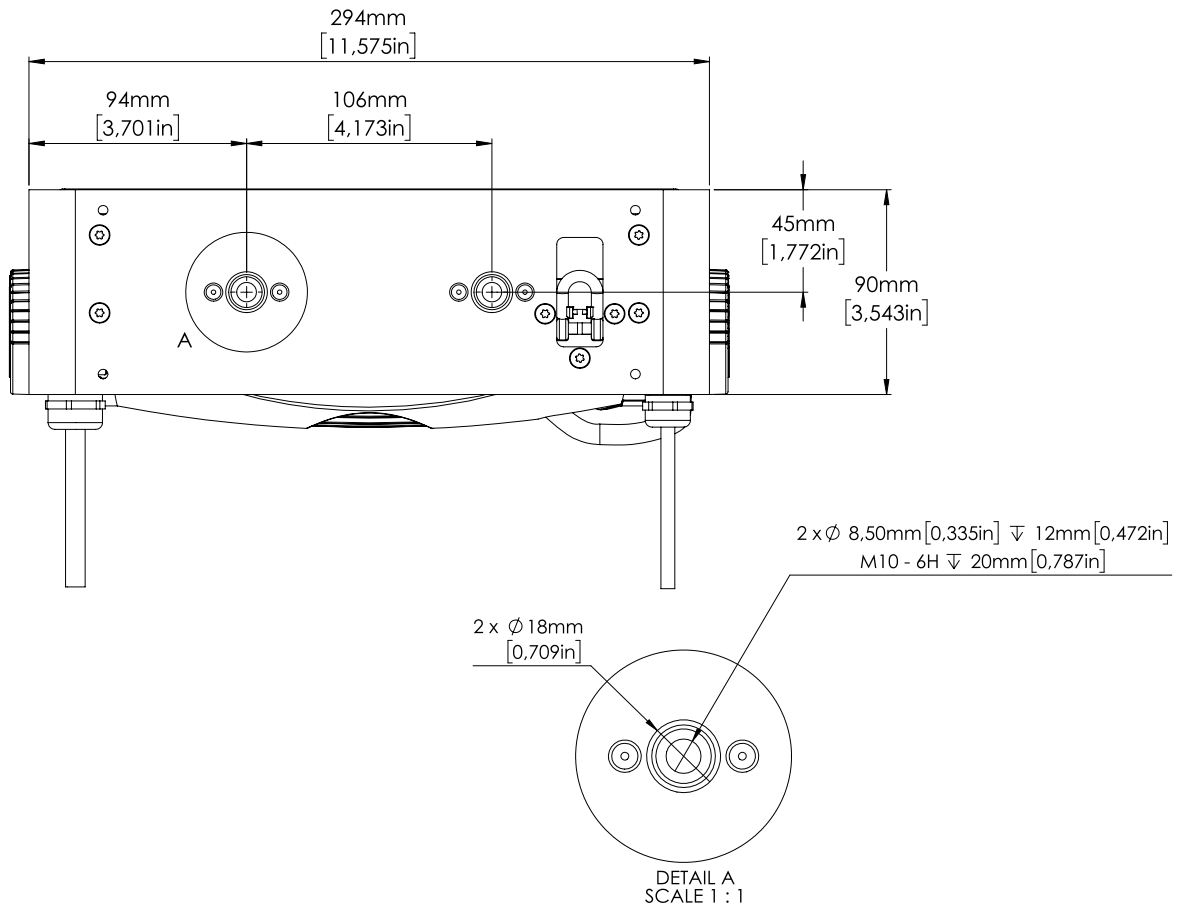

Figure 14: i-2 UVA POI base with dimensions

BRACKETS

There are four bracket choices available from SGM:



Flat bracket



Omega bracket



Wall mount bracket



Universal bracket

FLAT BRACKET ATTACHMENT

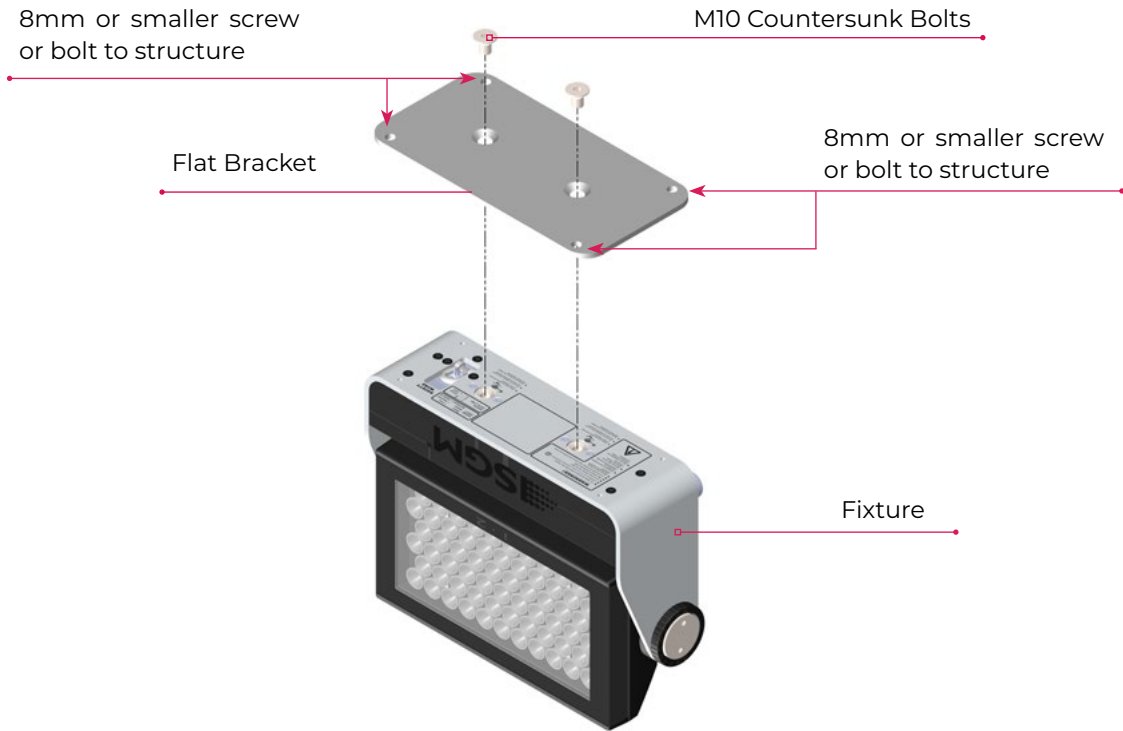

OMEGA BRACKET ATTACHMENT

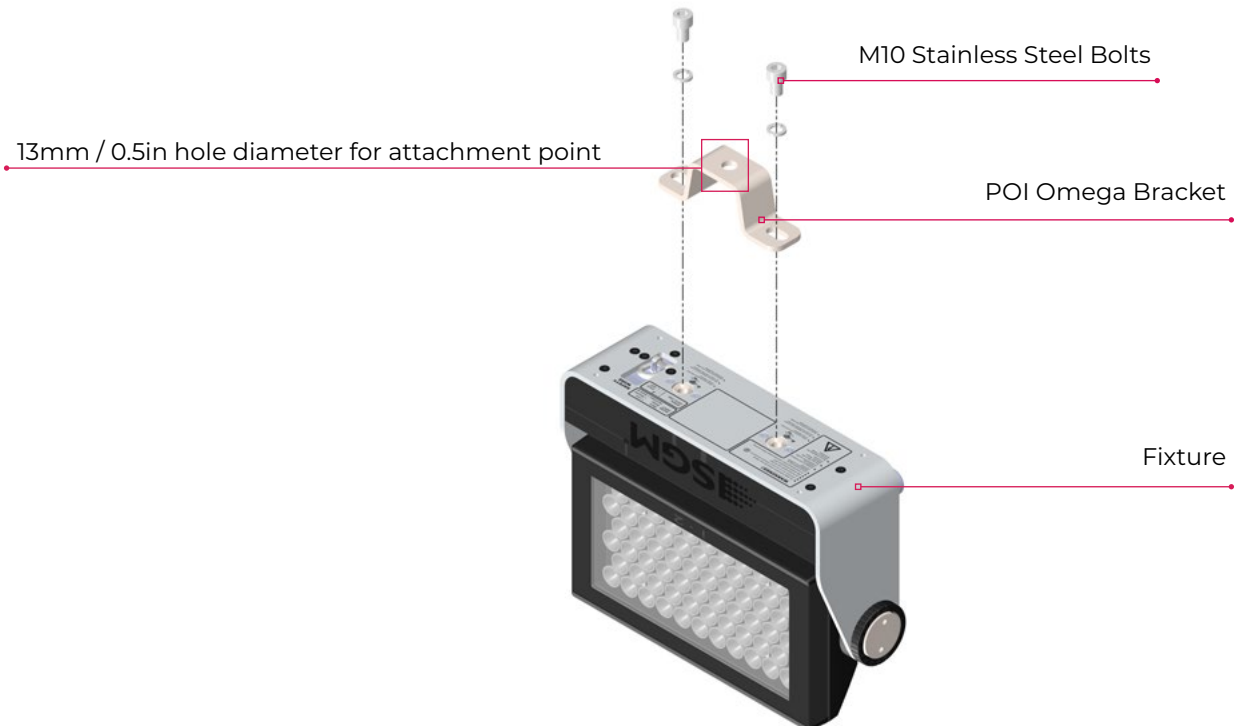

UNIVERSAL BRACKET ATTACHMENT

M10 Stainless Steel Bolts

Using a bolt through this slot, the fixture will rotate around its center point, always use 2 bolts with washers.

Using a bolt through this slot, the fixture will rotate around its center point, always use 2 bolts with washers.

POI Universal Bracket

Fixture

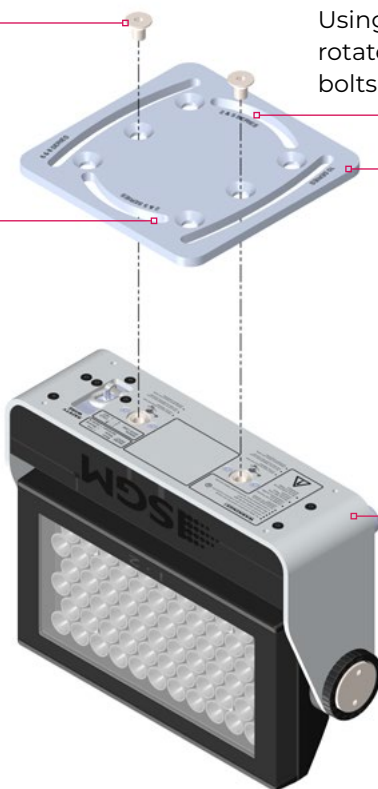

WALL BRACKET ATTACHMENT

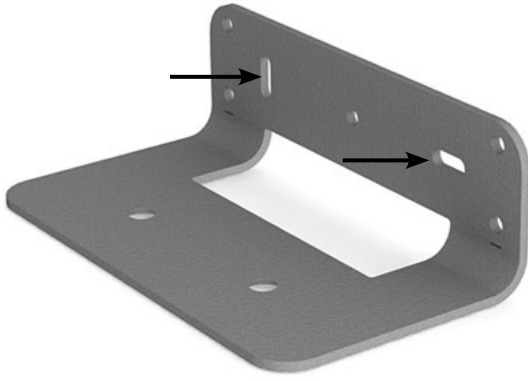

Attach and align the bracket to a surface. The shorter side of the bracket is the side that attaches to a wall surface. There are two slots provided to align the bracket. Using appropriate fasteners, align and level the bracket. Then tighten to the surface. Using the holes shown, use appropriately rated fasteners for both location and surface material and construction. Fasteners should be no larger than M6.

Alignment Slots

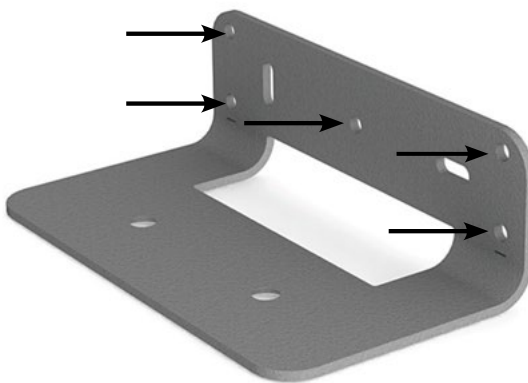

Wall Attachment Slots

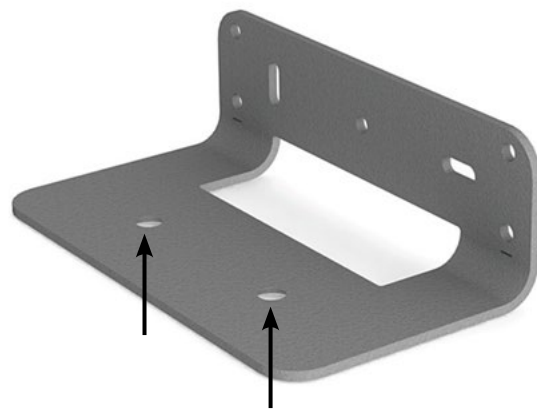

Fixture Attachment Slots



Use the supplied countersunk M10 bolts to secure the fixture to the bracket. Ensure cabling is not pinched or trapped when mounting fixture.

PLEASE NOTE! REMOVE RUBBER FEET FROM FIXTURE IF SO EQUIPPED PRIOR TO MOUNTING.

POI TILT LOCK

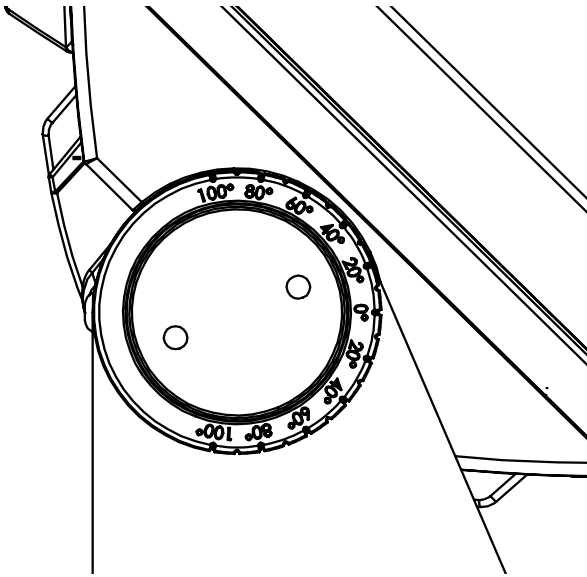

Figure 15: POI Tilt lock

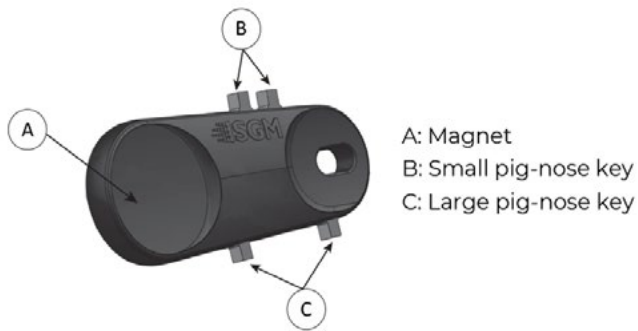

Figure 16: POI Spanner

CAUTION!

ALWAYS LEAVE A FIXTURE TO COOL OFF FOR 15 MINUTES AFTER OPERATION BEFORE HANDLING.

The tilt angle in POI fixtures may be adjusted by using the large pig-nose key provided in the spanner.

To adjust the tilt angle in POI fixture, take the following steps:

- Use the spanner and turn both tilt lock screws (one on each side) counter-clockwise by using the large pig-nose key. Screws are loosened by turning counter-clockwise.
- Tilt the fixture to the angle desired and hold it.
- Lock the position by tightening the tilt lock screws clockwise with the same pig-nose key.

The POI fixture includes a spanner with magnet to establish connection between the fixture and the wireless transmitter.

The spanner also has two types of pig-nose keys used for tilt adjustment in POI fixtures.

In POI fixture devices, the largest pig-nose key is used for tilt adjustment.

PERMANENTLY CONNECTING POWER & DATA

PLEASE NOTE! POI FIXTURES MUST BE TERMINATED IN SUITABLY IP RATED ENCLOSURES, AND WITH CABLE CONNECTIONS MEANT FOR DIGITAL DATA SIGNAL.

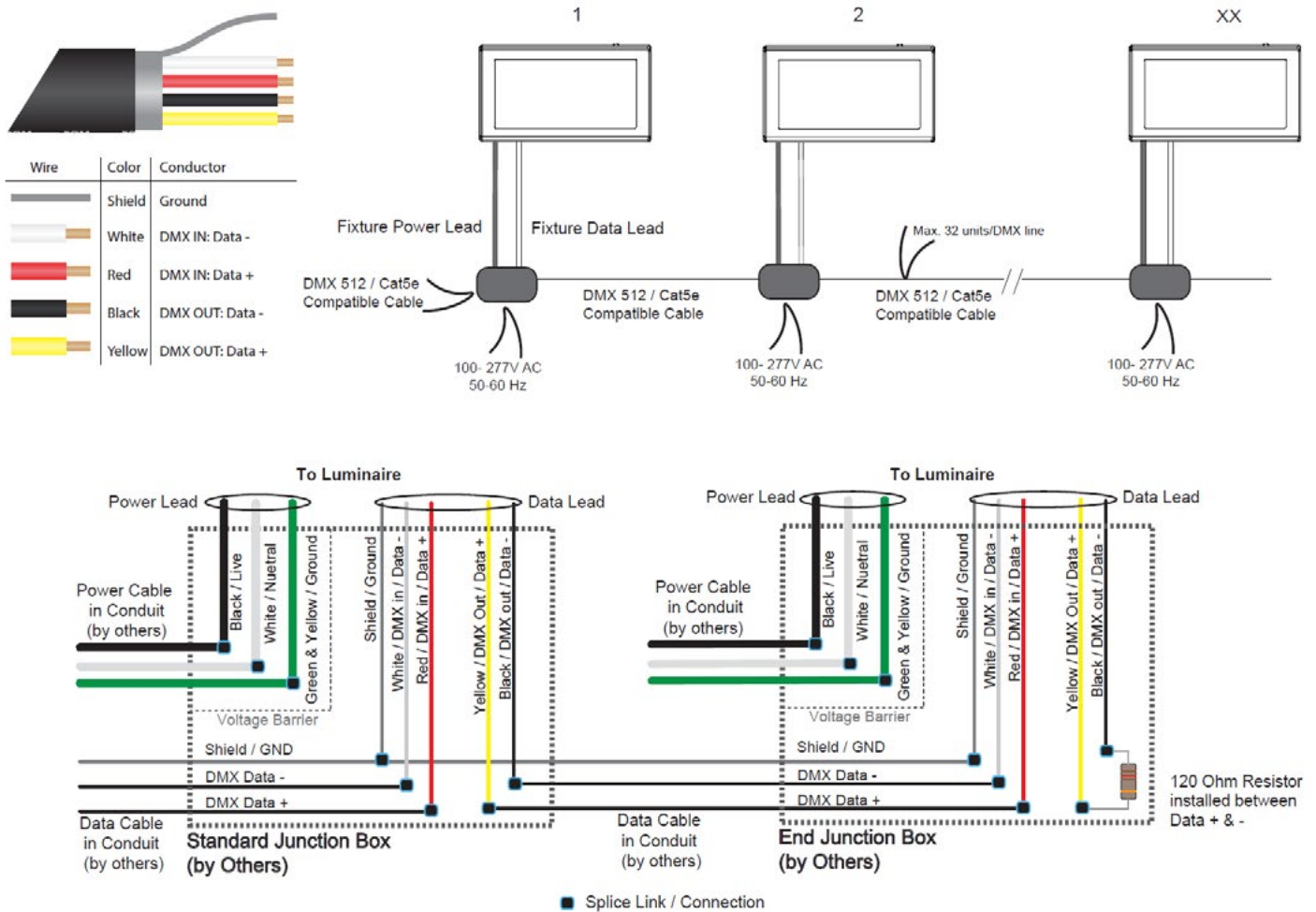

Figure 17: Connecting DMX and AC Power in POI

The last fixture in line must have a resistor installed between the yellow and black data out wires. This is to terminate the DMX signal, like to RS-485 signal protocol.

DMX in and DMX out are in the same cable. See more in figure above about the SGM POI DMX cable.

For permanent installations, have a qualified electrician wire the mains cable directly to a suitable branch circuit.

For a temporary installation, the mains cable may be fitted with a grounded connector intended for exterior use.

PLEASE NOTE!

- Cat5e compliant cable is suitable for the transmission of DMX 512 with RDM.
- Up to 32 fixtures can be on the same DMX link. Additional fixtures will overload the link.
- The last fixture must always be fitted with a DMX termination plug to the fixtures DMX out.
- SGM fixtures provide a passive DMX Thru signal as DMX Out, instead of an active output signal.

WIRELESS

In POI versions with wireless, it is necessary to pair the fixture with a new transmitter (by default, the fixture is linked to the SGM factory transmitter during the testing and QA process).

In order to do so, make sure the fixture is powered on before taking the following steps:

- STEP 1: Using a SGM magnetic spanner tool, place the magnet close to the LED indicator, and wait for 3 seconds. The LED indicator will blink orange for 1-2 seconds, before switching to static green again. The fixture can now be paired to a new transmitter.
- STEP 2: Select “connect” or “link” on a wireless DMX transmitter. The transmitter and the internal SGM receiver should now be linked together.

Repeat the process to link the fixture to another transmitter.

To disconnect the fixture from the currently paired wireless transmitter, hold the magnet for 3 seconds over the LED indicator. The LED indicator will blink orange for 1-2 seconds, switching later to green again. The fixture is now logged off.

USER INTERFACE

The fixture can be set up by using the control panel and OLED multi-line display, or through RDM.

PLEASE NOTE! IN POI VERSION, THE DISPLAY IS REPLACED BY AN INDICATOR LIGHT. SETUP AND CONFIGURATION IS DONE THROUGH RDM.

SEE “[POI PERMANENT OUTDOOR INSTALLATION](#)” FOR MORE INFORMATION.

The OLED display is the user interface of the fixture that displays the current status and menu of the fixture. The display panel can be used to configure individual fixture’s settings, check the fixture’s wireless status, confirm the firmware version, and read error messages. The complete list of the menu and all commands available are listed in “Control menu”.

Before turning on the fixture, make sure the power cable is properly connected. When the fixture is powered on, it boots and resets before displaying the selected operating mode and DMX start address. Navigate through the menus and options using the arrow buttons, and select items using the ENTER button.

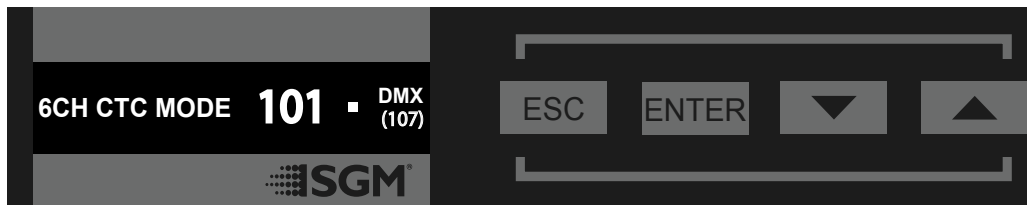

Figure 18: OLED display and control panel

USING THE DISPLAY PANEL

- Press the 'ENTER' button to access the menu or make a selection.
- Press the arrow buttons to scroll up and down in the menus.
- Press the 'ESC' button to take a step back in the menu.

SHORTCUTS

- ESC + ENTER: Press ENTER to confirm factory defaults.
- ESC + UP: Press ENTER to start LED test.
- UP + DOWN arrows simultaneously = flip the display upside-down.

OPERATIONAL MODE (A)

Displays the current mode (stand-alone or DMX mode). The fixture is set default to be controlled in DMX mode.

DMX ADDRESS (B)

Displays the current DMX address. The DMX address is altered directly from this view.

EXTERNAL DATA INDICATOR (C)

The DMX signal indicator will flash when the DMX signal is received.

EXTERNAL DATA PROTOCOL (D)

Shows the external data protocol (CRMTM or DMX).

- When 'DMX' is displayed: the fixture responds to data received through cabled DMX.
- When 'CRM' is displayed: the fixture responds to data received through wireless DMX.

The next available DMX address will show immediately, depending on the fixture's DMX footprint.

ERROR INDICATOR

If any errors are detected, the message 'ERR' will be flashing in the display for easy detection.

To read the error message, select ENTER → INFO → ERRORS in the menu.



- A - Operational mode
- B - DMX address
- C - External data indicator (DMX)
- D - External data protocol + next available DMX address

Figure 19: i-2 Display

ABOUT DMX

The fixture can be controlled by using signals sent by a DMX controller on a number of DMX channels.

DMX is the USITT DMX512-A standard, based on the RS-485 standard. The signal is sent as DMX data from a console (or a controller) to the fixtures via a shielded twisted pair cable designed for RS-485 devices.

Fixtures can be linked together in a daisy chain. Up to 32 fixtures can be connected to the same DMX link. Up to 300 m (1000ft) of cable is achievable with high quality DMX cables. All DMX links must be terminated by connecting a DMX termination plug to the last fixture's 5 pin DMX-out connector.

PLEASE NOTE! STANDARD MICROPHONE CABLE IS NOT SUITABLE FOR TRANSMITTING DMX. UP TO 32 FIXTURES CAN BE LINKED TO THE SAME DMX CHAIN. ADDITIONAL FIXTURES WILL OVERLOAD THE LINK.

DMX START ADDRESS

The fixture can be operated in different DMX modes. For any of the modes, the first channel used to receive data from a DMX control device is known as the DMX start address.

For independent control, each fixture must be assigned its own DMX start address. For example, if the first fixture is set to 2ch 16-bit DMX mode with a start DMX address of 101, the following fixture in the DMX chain should then be set to a DMX address of 103. As the first fixture uses the first 2 DMX channels, including channel 101, the next available channel is 103 (101+2=103).

If two or more fixtures have the same DMX start address, they will behave identically. Incorrect settings will result in unpredictable responses from the lighting controller. Address sharing can be useful for diagnostic purposes and symmetrical control.

SET/EDIT DMX ADDRESS

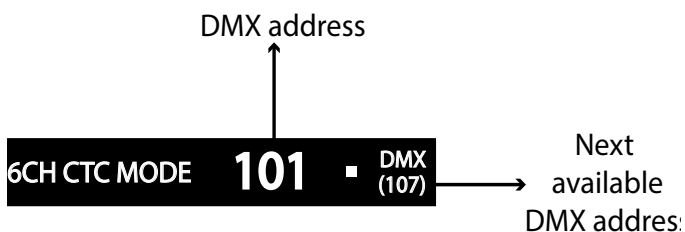

Figure 20: i-2 Display

The DMX address is shown on the OLED display in the control panel. To change the address setting, press the up and down arrows. When the desired address is displayed, press ENTER to save the setting. The next available DMX address is displayed to the right. Note that channel spacing is determined by the number of channels of the DMX mode.

See "Configuring the device" on page 13 for instructions on using the display panel.

The fixture also offers the option to set the DMX address through RDM.

PLEASE NOTE! POI VERSIONS ARE ADDRESSABLE VIA RDM. SEE POI PERMANENT OUTDOOR INSTALLATION.

SETTING THE DMX MODE

When selecting ENTER → MODE → SELECT MODE in the control panel, it is possible to choose the DMX mode that provides the controls that you require. Confirm the chosen mode by pressing 'Enter'.

DMX CHARTS

The fixture operates in different DMX modes. Each DMX mode has its own DMX chart. All DMX charts are available for download at www.sgmlight.com under the respective product, or upon request via support@sgmlight.com.

USING STANDALONE OPERATION

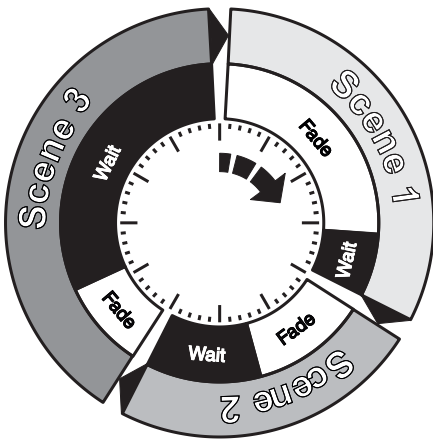

Figure 21: Standalone operation

Standalone operation is not running when the fixture is connected to a control device, but when it is pre-programmed with a series of up to 24 scenes, playing continuously in a loop. Up to three stand-alone programs can be defined and run from the menus, and one of the programs can be set to run by default whenever the fixture is powered on.

Each of the three available standalone programs contains 24 user-definable scenes with its own RGB and shutter settings.

Each scene has a definable fade-in time for the transition from one color to the next, and a wait (static) time of up to 120 minutes and 59 seconds.

To define a stand-alone program, press ENTER → MANUAL → EDITOR.

The standalone mode of the fixture's startup is enabled by selecting:

ENTER → SETTINGS → STARTUP MODE → SELECT STARTUP MODE → STANDALONE.

To select the fixture's startup program, press:

ENTER → SETTINGS → STARTUP MODE → STARTUP PROGRAM.

The chosen program will run its length cyclically whenever the fixture is powered on.

To run an internal program, go to:

- ENTER → MANUAL → RUN PROGRAM.

To stop an active internal program, go to:

- ENTER → MANUAL → STOP PROGRAM.

See "Control menu" on page 27 for detailed information about the manual menu.

PLEASE NOTE! IN POI VERSIONS, CONFIGURING THE FIXTURES IS DONE THROUGH RDM.

FACTORY DEFAULT

When restoring the fixture to the factory defaults, the following settings will be set:

1. Set DMX address to 1
2. Default DMX modes:
 - Single color and UVA fixtures - 2 Channel Shutter
3. Set screensaver to Dimmed
4. Disable Startup Programs
5. Set all Quick Color values to zero
6. Set all values in Manual Programs to zero
7. Set Fan mode to Standard
8. Set Frequency to Default

LED ENGINE

The fixture LED engine is comprised of 365nm wavelength ultra-violet LEDs. Extra care should be taken to avoid prolonged contact with UV light. Please refer to safety warnings at the beginning of this manual.

INDIVIDUAL FIXTURE SETTINGS

Setting the dimming curve

Setting the dimming curve will determine the fixture's behaviour, when changing the light intensity between 0% - 100%.

Linear control provides uniform adjustment throughout the control action, whereas gamma corrected dimming provides finer control at low light levels, where the eye is more sensitive to change. By default, the fixture uses gamma corrected dimming. For a uniform response, set all fixtures to the same dimming curve.

Flipping the OLED display (POI n.a.)

If the fixture is installed hanging upside down, it might be useful to flip the display so that it is easier to read.

To flip the display, press ENTER and select SETTINGS → FLIP DISPLAY, or press the up and down buttons on the control panel at the same time.

Setting the OLED display saver (POI n.a.)

By default the OLED display dims down after a short period when the control panel is not in use. The display can also be set to turn off completely. Pressing any key will turn on the display or restore it to normal brightness.

To configure the display settings, press ENTER → SETTINGS → DISPLAY SAVER.

PLEASE NOTE! TO AVOID THE RISK OF DISPLAY DETERIORATION CAUSED BY LONG TERM USAGE, IT IS RECOMMENDED TO SELECT SETTINGS → DISPLAY OFF.

Setting the fan mode

For environments where low-noise is a requirement, or where the fixture will be operating in high temperatures, it is possible to adjust the default fan speed by going to SETTINGS → FAN MODE in the menu. In POI versions, this is done via RDM.

PLEASE NOTE! IN POI FIXTURES, FAN MODE ADJUSTMENT IS DONE THROUGH RDM.

CONTROL MENU

LEVEL 1	LEVEL 2	LEVEL 3	LEVEL 4	FUNCTION
MODE	Select mode	-	-	Select DMX mode.
MANUAL	QUICK COLOR*	-	0-255	Static quick color (0-255). Sets fixture to quick color startup mode.
	RUN PROGRAM	1, 2 or 3	-	Runs internal sequence 1, 2 or 3.
	STOP PROGRAM	-	-	Stops current running internal sequence or Quick Color.
	EDITOR	Program	-	Edits scenes.
INFO	PRODUCT TYPE	-	-	Displays product type.
	FIRMWARE VERSION	-	-	Displays installed firmware version.
	SERIAL NUMBER	-	-	Displays fixture's serial number.
	RDM ID	-	-	Displays fixture's RDM ID. (Unique RDM ID for identification).
	DMX VIEW	Up to 492 DMX addresses	-	Displays received DMX channels.
INFO	SENSORS	Mainboard	-	Displays fixture's temperatures.
		LED Left	-	
		LED Center	-	
		LED Right	-	
	Humidity	-	Displays humidity percentage.	
	AC Connected	-	Displays whether power is connected or not.	
	Battery PCT	-	Displays battery level.	
	Charging	-	Displays whether the battery is charging or not.	
	Battery VDC	-	Displays battery voltage.	
	Wireless Signal	-	Displays wireless signal strength.	
	Wireless Paired	-	Displays wireless connection status.	
	POWER ON TIME	-	-	Displays fixture's total power on time.
	LED ON TIME	-	-	Displays LED's total power on time.
	ERRORS	-	-	Displays error codes.
SETTINGS	STARTUP MODE	SELECT STARTUP MODE	-	Default operating mode when fixture is powered on: 1. DMX (factory default). 2. Stand-alone. 3. Quick Color.
		STARTUP PROGRAM	Select startup program	
	LED FREQUENCY	SET LED FREQUENCY	-	Sets LED frequency.
	FLIP DISPLAY	-	-	Flips control panel display.
	DISPLAY OFF	-	-	Toggles automatic display sleep.
	FAN MODE	STANDARD	-	Controls fan's speed.
		SILENT	-	
		MAX POWER	-	
	FACTORY DEFAULT	-	-	Reset the fixture to factory default settings.
	SERVICE PIN	-	-	-
SERVICE MENU	-	-	-	
TEST	SELF-TEST	Start/stop self-test	-	Activates automated self-test.
	DISPLAY TEST	-	-	Tests the fixture's display.
	COLOR TEST	Start/stop color test	-	Tests the LED segments of the fixture.

* Quick Color programming in the i-2 UVA sets a preset level for all UV emitters, there is no color produced.

SUPPORTED RDM FUNCTIONS

The fixture features support for various RDM functions.

RDM (Remote Device Management) is a protocol enhancement to USITT DMX512 that allows bi-directional communication between the fixtures and the controller over a standard DMX line. This protocol will allow configuration, status monitoring, and management.

A RDM controller is needed to get control over the supported parameters. See the tables below for supported RDM functions.

PLEASE NOTE! THE RDM CONTROLLER COMMUNICATES WITH THE FIXTURES TO SHOW ONLY THE AVAILABLE OPTIONS FOR EACH RDM FUNCTION. TABLES ARE SUBJECT TO CHANGE WITHOUT NOTICE.

PID	ACTIONS ALLOWED	NAME
0x0082	GET/ SET	Device label
0x0081	GET	Manufacturer Label
0x00E0	GET/ SET	DMX Personality
0x00E1	GET	DMX Personality Description
0x0200	GET	Sensor Definition
0x0201	GET/ SET	Sensor Value
0x0080	GET	Device Model Description
0x0400	GET / SET	Device Hours
0x0051	GET	Parameter Description
0x0500 / 501	GET/ SET	Display Invert / Level (POI n.a.)

PID	ACTIONS ALLOWED	NAME
0x0090	GET/ SET	Factory Defaults
0x1001	SET	Reset Device
0x0120	GET	Slot Info
0x0121	GET	Slot Description
0x0122	GET	Default Slot Value
0x8626	SET	CRM Log Off
0x8060	GET	Serial number
0x8625	GET / SET	FAN 0=AUTO 1=LOW 2=HIGH 3=FULL
0x8620	GET / SET	Led freq (197647Hz) / value

SENSORS

RDM enables various sensor readouts for remote device monitoring. See the table below for sensors and sensor types.

PLEASE NOTE! THE RDM CONTROLLER COMMUNICATES WITH THE FIXTURES TO SHOW ONLY THE AVAILABLE SENSORS FOR THIS FIXTURE. THE TABLE IS SUBJECT TO CHANGE WITHOUT NOTICE.

NAME	SENSOR TYPE
Mainboard	Temperature
LED Left	Temperature
LED Center	Temperature
LED Right	Temperature
Humidity	Other
LED on Time Hours 1	Time
LED on Time Hours 2	Time
LED on Time Hours 3	Time
LED on Time Hours 4	Time

NAME	SENSOR TYPE
LED on Time Hours 5	Time
LED on Time Hours 6	Time
LED on Time Hours 7	Time
LED on Time Hours 8	Time
LED on Time Hours 9	Time
LED on Time Hours 10	Time
LED on Time Hours 11	Time
LED on Time Hours 12	Time

ACCESSORIES

The fixture can be used with various accessories such as barndoors, color frame, and anti-glare shields. To get to know all the available accessories, see www.sgmlight.com, or contact your local SGM dealer.



Figure 22 :i-2 UVA Accessory holder

ACCESSORY HOLDER

The Accessory holder is a mandatory base for holding barndoors and color frames of the fixture. It is a clip-on accessory that includes a safety wire intended to be attached to the bracket of the fixture, and a knob on the side to allow the sliding of barndoors, color frames or rigid diffusion filters.



Figure 23: i-2 UVA 8-way Barndoors

BARNDOORS

The fixture has 4-way and 8-way barndoors. The difference between the two types is that the 8-way barndoors give an extra control when cutting the light by extending and adjusting the width of the side flaps.

The barndoors are designed and intended to be mounted on the fixture without the use of any tools. Simply attach the accessory holder to the fixture and slide the barndoors from one side. Secure the barndoors with the help of the swivel arm on the side of the accessory holder and the locking knob attached to it.

The fixture barndoors are also compatible with the use of color frame and diffusion filters.



Figure 24 : i-2 UVA 4-way Barndoors

FLOORSTAND

The fixture has an optional floorstand available, ideal when there is a frequent need of changing the position of the fixture between hanging and standing.

The fixture floorstand is easy to mount or remove by using 1/4-turn fasteners.



Figure 25: i-2 UVA Floorstand

PLEASE NOTE! THE ACCESSORY HOLDER, THE BARNDOORS, AND THE FLOORSTAND ARE NOT INTENDED FOR PERMANENT OUT-DOOR INSTALLATIONS.



Figure 26: i-2 UVA Anti-glare Shields



Figure 27 : i-2 UVA Anti-glare Shields

ANTI-GLARE SHIELDS

The fixture features two different types of optional anti-glare shields:

- Full anti-glare shield - covers the full fixture's opening.
- Half anti-glare shield - covers half of the fixture's opening.

Using the anti-glare shields will remove any unwanted glare and reflections.

The anti-glare shields are easily mounted by removing the two tilt lock bolts, one on each side of the fixture. Refit the anti-glare shield in position and screw both tilt lock bolts again.

PLEASE NOTE THIS ACCESSORY IS SUITABLE FOR BOTH PERMANENT OUTDOOR AND INDOOR INSTALLATIONS.

FOR FURTHER INFORMATION AND OTHER POSSIBILITIES SEE WWW.SGMLIGHT.COM OR CONTACT YOUR LOCAL SGM DEALER.

MAINTENANCE

Updated maintenance procedures and frequency are available at www.sgmlight.com under the respective product.



Figure 28: SGM Vacuum Test Kit

SGM VACUUM TEST KIT

The Vacuum Test Kit is an accessory suitable for all SGM IP-rated fixtures, made for testing the IP integrity upon reassembly.

In order to ensure the IP-rating of the i-6 Series, it's highly recommended that the fixture is always vacuum tested after installing or swapping any part that might compromise the IP-rating, e.g., swapping the front lens.

SGM disclaims liability for any damage occasioned by the non-use, or inability to use, the vacuum test kit after reassembling the fixture.



Figure 29: SGM Uploader Cable

USB - XLR UPLOADER CABLE

The SGM USB to DMX cable is an accessory used mainly to update the fixture with the latest SGM firmware. See below how to update the fixture with the latest firmware.

The SGM Uploader cable is also used for controlling the DMX values channel by channel through the Firmware Uploader Tool software (available for download at www.sgmlight.com).



Figure 30: SGM Uploader cable POI

USB - POI UPLOADER CABLE

The SGM USB to DMX cable is an accessory used mainly to update the fixture with the latest SGM firmware. See below how to update the fixture with the latest firmware.

The SGM Uploader cable is also used for controlling the DMX values channel by channel through the Firmware Uploader Tool software (available for download at www.sgmlight.com).

FIRMWARE UPDATES

Fixture firmware can be identified in two different ways:

Standard Fixture

- When powering on a standard fixture, the display shows the current installed firmware version.
- Go to MENU → INFO → FIRMWARE VERSION (on standard).
- Through RDM

POI Fixture

- Connect either Std or POI uploader cable depending on which is more suitable for the installation
- Launch the SGM RDM Addressing Tool
- Click “Full Discovery” fixture should show in the chart. Firmware will be displayed in the firmware column

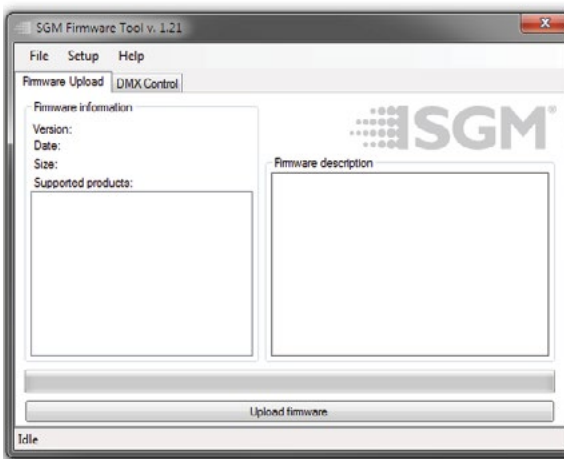

Figure 31: SGM Firmware tool

To update a fixture with the latest firmware, use an SGM USB 5-Pin-XLR uploader cable, and a Windows-based computer with the SGM Firmware Tool software installed

(available for download at www.sgmlight.com).

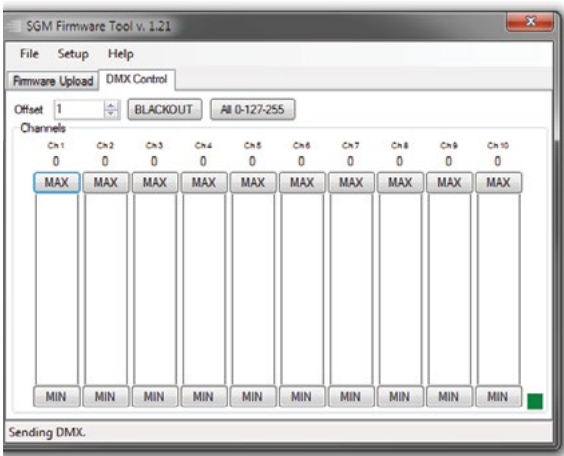

Figure 32: SGM Firmware tool

- Download the SGM Firmware Tool software from the SGM website
- Download latest firmware file from product web page on the SGM website
- Connect either Std or POI uploader cable depending on which is more suitable for the installation
- Launch SGM Firmware Tool on a windows PC
- Click “File” then “Open” and navigate to the firmware file needed, select it and click “Open”
- The firmware is now loaded in the uploader, click “Upload Firmware”

The fixture will now update and reboot

The Firmware Tool software offers a simple DMX controller featuring 512 DMX channels for test purposes.

IT IS RECOMMENDED KEEP FIRMWARE UPDATED. THE LATEST FIRMWARE VERSION IS ALWAYS AVAILABLE FOR DOWNLOAD UNDER THE RESPECTIVE PRODUCT AT WWW.SGMLIGHT.COM.

CLEANING

SGM fixtures with IP65 or IP66-rating do not need any cleaning procedures inside the fixture. However, cleaning the front lens may be needed to achieve the maximum light output after exposure to dust, sand, or dirt. The exterior housing can also be cleaned to get a better look. To maintain adequate cooling, fans must be cleaned periodically.

Whenever necessary, clean the fixture using a soft cloth dampened with a solution of water and a mild detergent. Do not use products that contain solvents, abrasives, or caustic agents for cleaning, as they can cause damage to hardware, cables, and connectors.

The level of cleaning required will vary greatly depending on the operating environment and installation. Therefore, it is recommended to do frequent check-ups the first few weeks of operation to see how often cleaning is necessary.

TROUBLESHOOTING

PROBLEM	POTENTIAL CAUSE(S)	REMEDIES
Fixture does not respond or appears to be off.	No power to the fixture.	Confirm that the power is switched on, confirm that the cables are plugged in.
	Main fuse is blown.	Contact your local SGM dealer or support@sgmlight.com.
Fixture suddenly turned off.	Power was turned off.	Check the power supply, switches and breakers.
Fixture suddenly stopped responding.	The DMX console was disconnected/tampered with.	Inspect the DMX console and connections.
	DMX cables were disconnected.	Inspect DMX cables.
Fixture operates irregularly/abnormally.	DMX cable polarization is inverted (pin 2 + 3).	Reverse the polarity.
	DMX link is not terminated.	Install a XLR 120ohm DMX termination at the end of the DMX link.
	Corrupted DMX cable.	Replace or repair defective cables and/or connections.
	The fixture operates an internal program.	Go to MENU → MANUAL → STOP PROGRAM.
	A corrupted fixture generates noise/disruptions on the DMX link.	Track and isolate the corrupted fixture.
"Firmware not loaded" in display (POI n.a.)	The RFD is malfunctioning.	Contact your local SGM dealer or support@sgmlight.com.
Color is uneven in low output	The minimum values are out of calibration.	Contact your local SGM dealer or support@sgmlight.com.
	The SGM Calibration Data set has been lost.	Contact your local SGM dealer or support@sgmlight.com.

FIXTURES AND ACCESSORIES

PLEASE NOTE! THE LIST BELOW IS SUBJECT TO CHANGE WITHOUT NOTICE.

ORDERING INFORMATION

i-2 UVA Wash, 8.5 deg. P/N: 80031190 / 80031191

i-2 UVA, POI, BL P/N: 80231800 / 80231801

The i-2 UVA can be ordered in any RAL color, and with honey comb at request. Contact your local SGM dealer for ordering customized color housings or for more information.

i-2 UVA accessories

Omega bracket w/Q-bolt, BL/WH P/N: 83060602 / 83061206

Omega bracket POI with M10 screws, BL/WH P/N: 83060623 / 83060624

USB uploader cable P/N: 83062011

USB POI uploader cable P/N: 83062067

Floorstand for i-2/P-2/Q-2 P/N: 83060613

Accessory holder i-2/P-2 Series, BL P/N: 83061127

Barndoor 4-way, i-2/P-2/Q-2 Series, BL P/N: 83061129

Barndoor 8-way, i-2/P-2/Q-2 Series, BL P/N: 83061130

Color frame, i-2/P-2/Q-2 Series P/N: 83061131

Half anti-glare shield, small, BL P/N: 83061161

Full anti-glare shield, small, BL P/N: 83061164

Honeycomb for i-2 UVA P/N: 36800040

Flight case for 4 pcs of P-2/Q-2 incl. barndoors P/N: 82051503

SGM vacuum test kit P/N: 83061136

Barndoor 4-way, barndoor 8-way, or color frame requires one accessory holder (Item No. 83061127) per fixture.

SUPPORT HOTLINE

SGM offers 24/7 technical support.

Worldwide: +45 3840 3840

US: +1 407-242-6217

support@sgmlight.com

APPROVALS AND CERTIFICATIONS

Conforms to 2014/35/EU: Low Voltage Directive
Conforms to 2014/30/EU: EMC Directive
Conforms to 2011/65/EU: RoHS2 Directive Pending
Conforms toANSI/UL Std. 1573
Certified to.....CSA E60598-1, Ed: 3
Certified to..... CSA-E598-2-17-98, Ed: 1
Conforms to UK SI 2016 No. 1101: The Electric Equipment (Safety) Regulations 2016
Conforms toUK SI 2016 No. 1091: Electromagnetic Compatibility Regulations 2016
Conforms toUK SI 2012 No. 3032: Restriction of the Use of Certain Hazardous Substances
in Electrical and Electronic Equipment Regulations 2012 (RoHS2)



The information in this document is subject to change without notice.
For the latest information, visit www.sgmlight.com.



SGM LIGHT A/S

Sommervej 23

8210 Aarhus V

Denmark

Tel: +45 70 20 74 00

info@sgmlight.com

www.sgmlight.com